

High-Resistance Grounding of Low-Voltage Systems: A Standard for the Petroleum and Chemical Industry

John P. Nelson, *Fellow, IEEE*, and Pankaj K. Sen, *Senior Member, IEEE*

Abstract—A debate has existed in the petroleum and chemical industry for years concerning low-voltage (480–600 V) power systems grounding. Since reliability and continuity of service are very important, some engineers in the past preferred using an ungrounded system. The practicality of such ungrounded system becomes questionable as the extent of coverage increases. Few ungrounded low-voltage systems are presently being designed due to the possible destructive nature of transient overvoltages resulting from an arcing ground fault. Most systems now utilize either a solidly grounded or high-resistance grounded source. This paper begins with a brief discussion on ungrounded, solidly grounded, and high-resistance grounded systems. Benefits and limitations of each system are also discussed. It is shown that the use of high-resistance grounded low-voltage systems makes good sense in the petrochemical industry. Design, construction, operation, and maintenance factors for such systems are discussed and analyzed together with systems when three-phase four-wire loads are present. Finally, operational problems and some appropriate solutions are discussed where significant variable-speed drive loads are utilized. It is suggested that this should become a standard of the industry and the solidly grounded system should be used only in applications where the high-resistance grounded system becomes impractical.

Index Terms— Grounding, high-resistance grounding, low-voltage system grounding.

I. INTRODUCTION

RELIABILITY has always been an important aspect in the design and operation of a low-voltage (LV) power system, particularly in the petrochemical industry. In this paper, LV refers to voltages in the 440–600 V range. Loss of LV power can cause a complete upset to a plant, create personnel and equipment safety problems, have an adverse environmental impact, and can result in substantial economic losses. As such, the need for a safe, reliable LV power source is essential.

In the past, an ungrounded power system was extensively used with the assumption that it is more reliable. However, experiences with multiple failures due to arcing ground faults have resulted in a change in philosophy about the use of the ungrounded system. Solidly grounded and high-resistance

grounded systems have become the standard for large industrial complexes. Solidly grounded systems may have their place where redundant equipment is installed and are the norm for three-phase four-wire systems.

A solidly grounded system provides some interesting problems. As the source transformer becomes larger, the available fault current increases substantially. Since the vast majority of faults are ground faults, the resulting damage can be great. Arcing faults can also present a serious problem, in that the arc voltage may become sufficiently high to limit ground fault currents to such low values that the fault current magnitude may fall within the load current range. Prior to the introduction of ground-fault protection, there were many cases where an arcing fault occurred on a circuit and went undetected until the fault propagated into a multiple-phase fault, cleared itself, or was manually disconnected by an operator. Such faults may last for many minutes and do extensive damage.

With the NEC 230-95 requirement for ground-fault protection on service entrances 1000 A and larger, and the utilization of ground fault protection on many other circuits, the number of sustained ground faults has been reduced. However, the number of cases of miscoordination of protective devices has increased. There have been numerous cases of ground faults occurring on downstream protective devices and tripping the main breaker. The result is that an entire plant may be shut down due to miscoordination caused by the ground-fault protective device.

The solidly grounded system can present problems with reliability and coordination. As a result, the high-resistance grounded system, if properly installed, can be superior to any other type of grounding system. The use of the high-resistance grounded system can provide a safe, reliable, and economic system with many benefits to the user.

II. HISTORY OF LV GROUNDING

There are several methods of grounding which have been used on LV systems. In the past, the ungrounded, the corner-grounded and the midpoint-grounded systems (Fig. 1) were used with varying degrees of success. Today, the solidly grounded and high-resistance grounded systems (Fig. 2) are the two most commonly used methods of grounding.

The *ungrounded system* is really a misnomer, in that the system is actually grounded through the capacitance, as shown in Fig. 3. As a result of this capacitance, a certain amount of capacitive current will always flow during a line-to-ground fault. In addition, it has been found that arcing ground faults on the large “ungrounded” system can cause transient over-

Paper PID 97-01, presented at the 1996 IEEE Petroleum and Chemical Industry Technical Conference, Philadelphia, PA, September 23–26, and approved for publication in the IEEE TRANSACTIONS ON INDUSTRY APPLICATIONS by the Petroleum and Chemical Industry Committee of the IEEE Industry Applications Society. Manuscript released for publication March 25, 1997.

J. P. Nelson is with NEI Electric Power Engineering, Inc., Arvada, CO 80001-1265 USA (e-mail: neil9@idt.net).

P. K. Sen is with the Department of Electrical Engineering, University of Colorado, Denver, CO 80217-3364 USA (e-mail: psen@carbon.cudenver.edu).

Publisher Item Identifier S 0093-9994(99)05375-X.

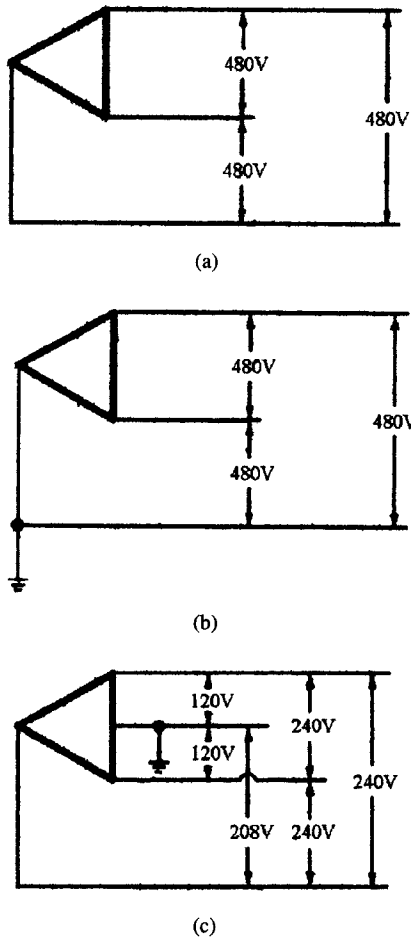

Fig. 1. Grounding of LV delta-connected system. (a) Ungrounded 480-V system. (b) Corner-grounded 480-V system. (c) midpoint-grounded 120/240-V system.

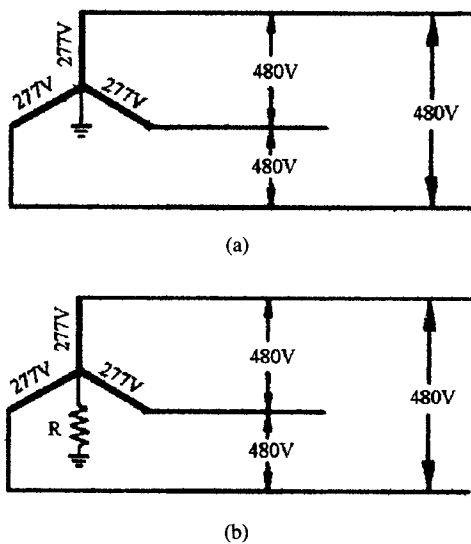

Fig. 2. Grounding of LV wye-connected system. (a) Solidly grounded. (b) Resistance grounded.

voltages several times the normal voltage [10], which may cause motor failures.

The *corner-grounded system* was one attempt to provide grounding. Although a simple system, there are several distinct disadvantages with this design.

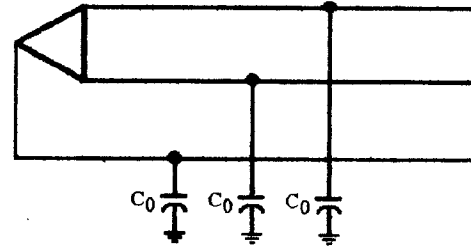

Fig. 3. Capacitive grounding.

- Normal line-to-ground voltages on the two ungrounded legs are at line-to-line voltage, which is 73% greater than normal line-to-ground voltage on a grounded three-phase wye-connected system.
- A ground fault on the grounded leg can go undetected.
- A ground fault on one of the two grounded legs will, in actuality, be a phase-to-phase fault with a ground path.

The *midpoint-grounded system*, commonly referred to as a three-phase four-wire delta, was a system which allowed both three-phase and one-phase loads. Electric utilities commonly used this connection in providing a three-phase four-wire 240-V power and center tapping one 240-V leg for 120-V lighting service. Electric utilities, while still utilizing this design, have largely done away with the three-phase four-wire delta 240- and 480-V systems and replaced them with 208 (Y)/120-V and/or 480 (Y)/277-V systems, respectively. Likewise, large power utilization customers prefer the 480 (Y)/277-V system.

III. COORDINATION PROBLEMS

National Electrical Code (NEC) Article 230-95 requires ground-fault protection of equipment rated 150 V or greater to ground, but not exceeding 600 V phase-to-phase for each service disconnect rated 1000 A and above. In reviewing this code requirement, two observations can be made.

- Ground-fault protection on systems with line-to-ground voltages of less than 150 V do not require ground-fault protection. Part of this reason is due to the fact that the arc voltage on an LV system is in the range of 140–150 V [6]. For a system voltage of approximately 150 V or less, there is normally insufficient voltage to sustain an arcing fault. The fault either welds itself to another conductor, causing sufficient fault current to clear the protective device, or the fault is self clearing by tripping a breaker and/or extinguishing the arc.
- With arc voltages in the range of 150 V, ground-fault currents on a 440–600 V system are often times limited to relatively low values. In the past, phase-sensitive protective devices with high current ratings have failed to clear arcing ground faults. The 1000-A rating appears to be the code-accepted lower limit where sustained arcing ground faults may occur and ground-fault protection is necessary. The actual value may be lower.

One of the fine print notes (FPN no. 2) of Article 230-95 states:

The added (ground fault) protective equipment at the service equipment may make it necessary to review

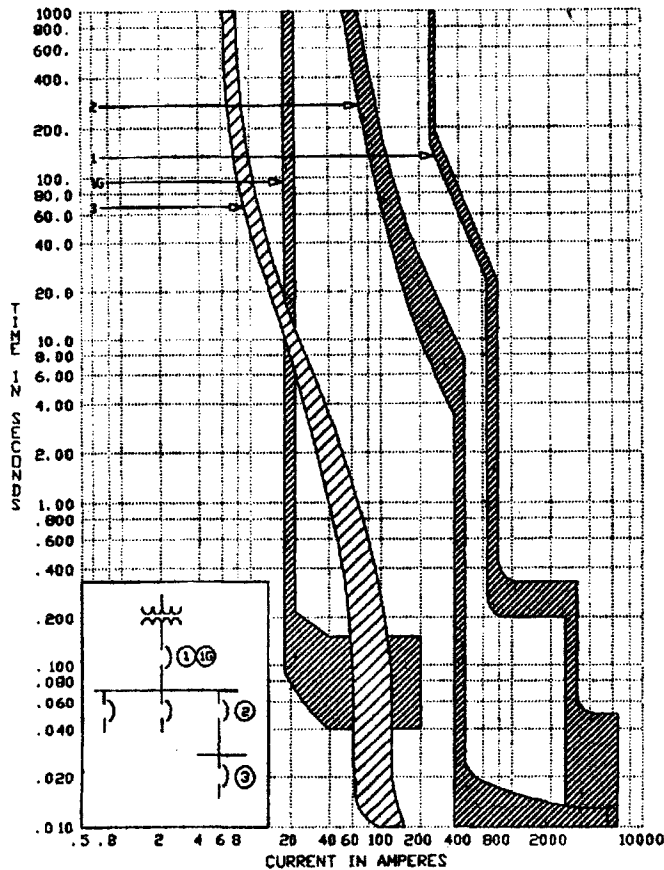

Fig. 4. Typical protection coordination problems. Device 1: main breaker phase protection. Device 1G: main breaker ground protection. Device 2: feeder breaker protection. Device 3: remote breaker protection.

the overall wiring system for proper selective overcurrent protection coordination. Additional installations of ground-fault protective equipment may be needed on feeders and branch circuits where maximum continuity of service is necessary.

Ground-fault protection on solidly grounded systems provides a more sensitive means of detecting and isolating ground faults than fuses and circuit breakers without ground-fault protection. The major benefit of ground-fault protection is the relatively quick and sensitive detection and isolation of circuits having a ground fault. However, along with the quick and sensitive detection of ground faults comes the problem of miscoordination, as mentioned in FPN no. 2 associated with NEC Article 230-95. Numerous cases have been reported and observed where a main breaker trips for a fault on an insignificant downstream feeder or branch circuit. In fact, the most common coordination problems at 440–600 V is caused by having a downstream phase device which miscoordinates with an upstream ground-fault protection, as depicted in Fig. 4.

In Fig. 4, the main breaker, device 1, has a combination of both phase and ground-fault protection as shown by phase time-current curve number 1 and ground-fault time-current curve number 1G. The feeder breaker, device 2, has no separate ground fault protection and its time-current curve is number 2. A downstream branch breaker, device 3, also has no separate ground-fault protection and its time-current

curve is number 3 (this breaker could easily be a minor, insignificant circuit breaker in the circuit). As can be seen, the phase protection curve of circuit breaker number 2 does not coordinate with the ground-fault protection curve 1G of the main breaker device 1. Furthermore, the time-current curve for circuit breaker number 3 does not totally coordinate with the main breaker ground-fault curve. The result is that the main breaker will open for most ground faults downstream of the feeder breaker before the feeder breaker can operate. Furthermore, circuit breaker number 3 also does not properly coordinate with the ground-fault protection on the main, and the main breaker can trip for a ground fault associated with breaker number 3. This type of miscoordination is quite common when a service disconnect is installed without a coordination study. False tripping can occur on downstream breakers rated as low as 20 A and is almost always a problem with downstream breakers rated 75 A and above. Better coordination can be obtained by performing a detailed short-circuit and coordination study in conjunction with installing downstream ground-fault protective devices. However, in most cases, compromises must be made, and maximum reliability is not attained using a solidly grounded system at 440–600 V.

IV. ARCING FAULTS AND ARC RESISTANCE

Short-circuit and coordination studies are commonly performed considering only bolted three-phase or phase-to-ground faults. However, real-life equipment failures rarely are bolted faults. Instead, the faults are normally arcing type, which has arc resistance, and this resistance must be taken into consideration. It has been shown that, on LV equipment, an arc voltage in the range of 150 V is developed. This voltage is relatively insensitive to current, which means the arc resistance is variable. Two observations can be made from this information.

- A sustained arcing fault is unlikely for systems with line-to-ground voltages of less than 150 V. In other words, a 208 (Y)/120-V system will not likely sustain an arcing fault. Conversely, LV systems with line-to-neutral voltages in excess of 150 V are much more likely to sustain an arcing fault. For example, a 480 (Y)/277-V system has sufficient voltage to maintain the arc.
- The arc resistance will tend to vary in order to maintain the arc voltage of 150 V. As such, the current magnitude may be limited to a value below the phase-current-sensing protective device. (With a sustained arcing fault and limited ground-fault currents, the explanation for sustained arcing faults at 480 V is clear.)

Sustained arcing in 480-V ground faults were a major problem prior to the extensive use of ground-fault protection. The use of ground-fault protection has minimized the damage caused by arcing faults which could not be cleared by insensitive phase protective devices, which were sized for large continuous currents of 1000 A and more.

In addition to equipment damage, the flash and heat from an arcing fault can cause severe injuries or death. Temperatures greatly in excess of 10 000 °C can be created almost instantaneously from the plasma of the fault [11]. The ionization

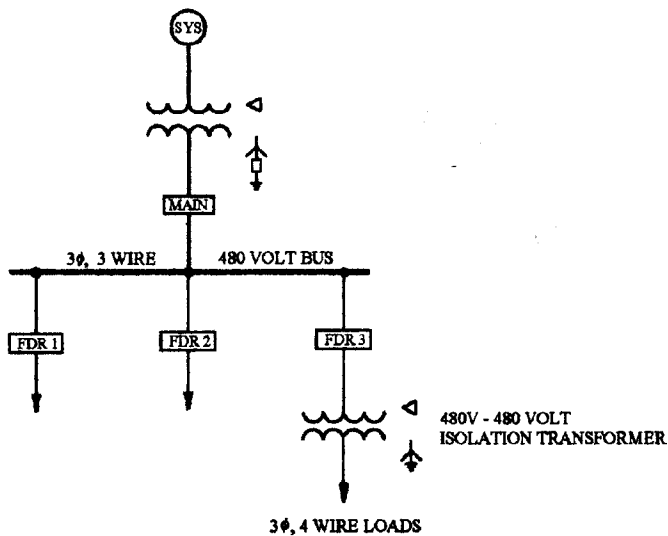

Fig. 5. High-resistance grounded main system with three-phase four-wire lighting loads.

gases expand at an extremely high rate, which will engulf any person or thing in its path.

The use of a high-resistance grounded system minimizes the amount of damage created from the fault by the following.

- It reduces the fault current to some smaller values, typically 1–5 A. The I^2t for a 1-A fault is 1/1 000 000 of a 1000-A fault, assuming an equal amount of time (t). Therefore, using high-resistance grounding drastically reduces the energy normally dissipated in a ground fault.
- By creating a voltage drop across the neutral grounding resistor, the remaining voltage at the point of the ground fault is much less than 150 V. Therefore, a sustained arcing fault is not likely.

V. HIGH-RESISTANCE GROUNDING AND THREE-PHASE FOUR-WIRE LOAD APPLICATIONS

One of the most common reasons for not using a high-resistance grounded system is that, in any typical power system, one-phase or three-phase four-wire loads are to be fed. If the majority of the loads are three-phase four-wire loads, high-resistance grounding is most likely not practical. However, if most of the loads are three-phase three-wire-type loads (motor loads), high-resistance grounding may still be an option.

With proper planning, many one-phase line-to-neutral loads can be replaced with line-to-line equipment. All step-down transformers, such as the 480 V–208 (Y)/120-V transformer, should utilize a delta primary, which equates to a three-phase three-wire load.

If three-phase four-wire loads are essential, a delta-wye isolation transformer may be installed to isolate the three-phase four-wire loads, as shown in Fig. 5. The delta winding provides the three-phase three-wire load required for the high-resistance grounded system, while the secondary 480 (Y)/277-V winding provides the ground source for three-phase four-wire loads. The wye on the secondary of the isolation transformer would be solidly grounded. Also, normally, the

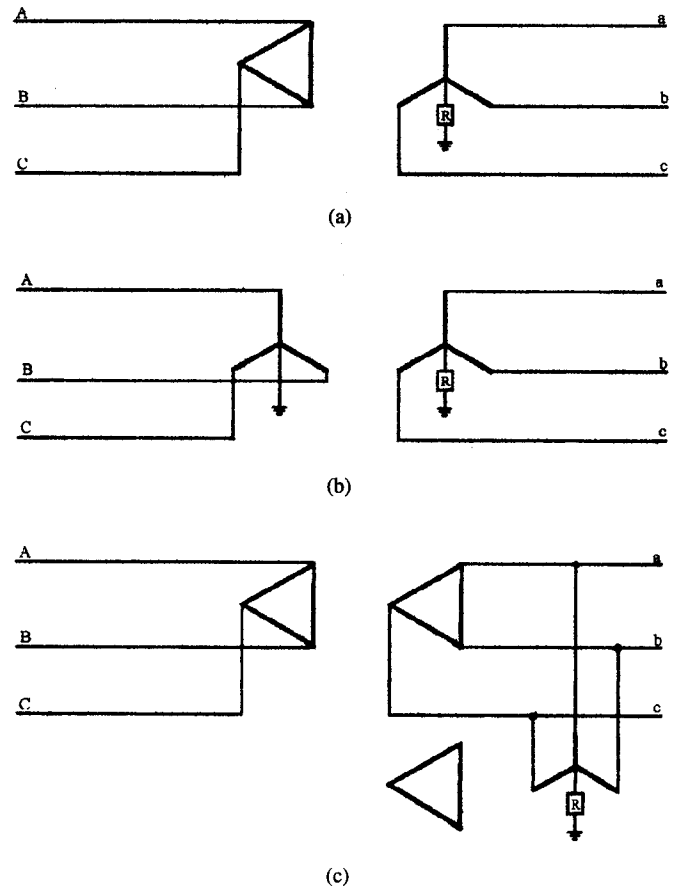

Fig. 6. High-resistance grounding. (a) Delta-resistance-grounded wye. (b) Grounded wye-resistance-grounded wye. (c) Delta-delta with retrofit resistance-grounded.

size of the transformer secondary breaker will be sufficiently small that ground-fault protection is inherent with the phase-current-sensitive breakers.

VI. DESIGN CONSIDERATIONS

The design of a high-resistance grounded system is relatively simple for a delta primary-wye secondary transformer. Similar concepts can be used with a wye-wye transformer provided the primary neutral bushing H_o and the secondary neutral bushing X_o are separate. The H_o bushing should be solidly grounded and the X_o bushing can be high-resistance grounded. The delta-connected secondary transformer, however, requires additional design calculations and equipment, since an auxiliary high-resistance grounded wye-delta transformer is required. Fig. 6 showing the grounding is self-explanatory.

The first step in the design is to calculate the system capacitance X_c . Reference [17] provides many typical capacitance values for low- and medium-voltage equipment. Although the accuracy is not critical in this calculation, the conservative approach would be to err on the high side for the system capacitance. During the testing phase, the actual charging (capacitive) current will be measured to verify the adequacy of the grounding resistor.

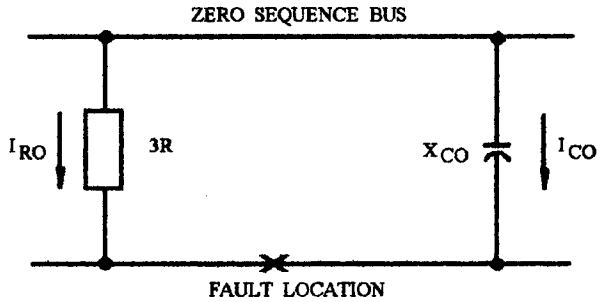

Fig. 7. Zero-sequence network of high-resistance grounded system.

After determining the system capacitance, a tapped ground resistor may be adjusted for proper size. In order to minimize the probability of transient overvoltages [9], the resistive current I_{RO} during a ground fault should be equal to or greater than I_{CO}

$$I_{RO} > I_{CO}. \quad (1)$$

In the zero-sequence circuit shown in Fig. 7, the resistor and equivalent capacitance are in parallel. Since the resistor is placed in the neutral of the transformer, the zero-sequence current $3I_o$ will flow through it. As a result, that current makes the apparent resistance of the grounding resistor appear to be three times as large. Therefore, $3R$ is used in the zero-sequence circuit [2]. Based on the circuit in Fig. 7 and the fact that the positive- and negative-sequence impedance values are negligible, good approximations for the resistance and current flows are as follows:

$$R = \frac{X_{CO}}{3} \quad \Omega \quad (2)$$

$$I_R = \frac{V_N}{R} \quad \text{A} \quad (3)$$

$$I_C = \frac{V_N}{X_{CO}/3} \quad \text{A}. \quad (4)$$

Note that $I_R = 3 * I_{RO}$ and $I_C = 3 * I_{CO}$ from symmetrical component calculations.

The resistor size (wattage) may be determined by the following equation:

$$\text{watts} = I_R^2 * R \quad \text{W}. \quad (5)$$

Typical resistance and wattage range for 480-V grounding resistors are as follows:

resistance range 60–300 Ω ;

wattage range 260–1300 W.

The grounding resistor is normally provided with taps, which allow for fine tuning of the resistance during the time of installation and testing. The authors' experience has been that the capacitive test current is usually somewhat lower than the calculated value. This is based on the conservative nature of the calculations and allowances can be made for future expansion and addition of equipment.

Once the capacitance of the system and the size of the grounding resistor have been determined, the specific detailed design and options for the system can be made. Fig. 8 shows a typical design with some installation, testing, and operational features.

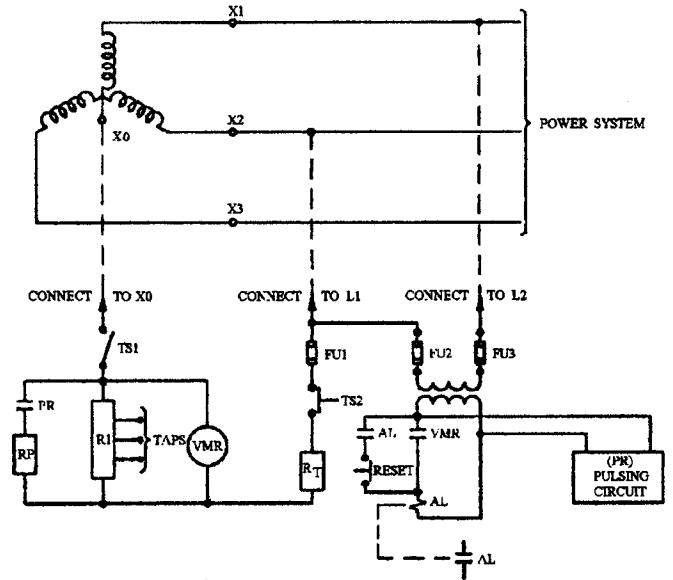

Fig. 8. High-resistance grounded system detail schematic. AL: alarm/tripping relay. R1: tapped grounding resistor. RP: pulsing resistor. PR: pulsing relay. TS1: resistor disconnect switch. TS2: ground test switch. VMR: voltage meter relay. FU1, FU2, FU3: fuses.

The basic design will include the tapped grounding resistor and a voltmeter relay (VMR). The relay provides for a voltage reading across the resistor and an adjustable voltage relay with one or more contacts. The VMR contact can be used for either tripping or alarming.

The optional feature should include a second fused switch and resistor for providing a ground-fault test. The second option could include an isolating transformer and an alarm or tripping seal-in control circuit. Finally, a pulsing relay circuit could be installed to aid in locating the ground fault. The pulsing circuit places another resistor in the circuit to allow more current to flow so that a clamp-on ammeter could be used to locate the fault.

VII. APPLICATIONS FOR HIGHER HARMONIC CURRENTS

Many LV systems have loads which produce harmonic current and voltage distortions. These distortions are created by rectifiers, dc drives, variable-speed ac drives, and other electronic switching devices which are connected to the power system. Without the drives, the capacitive current at 60 Hz is normally a positive-sequence value under steady-state conditions, and the currents cancel. However, many drives create a zero-sequence voltage and, when coupled with the earth, will create a high-frequency zero-sequence current to flow in the neutral grounding resistor. The result is that the high-frequency zero-sequence current will flow through the resistor, creating a high-frequency voltage of significant value. This voltage can result in the following:

- nuisance alarms and/or trips due to the rms voltage across the resistor;
- resistor sizing problems due to the harmonic current flow (the resistor sizing must include the heating effects caused by the harmonic current flow).

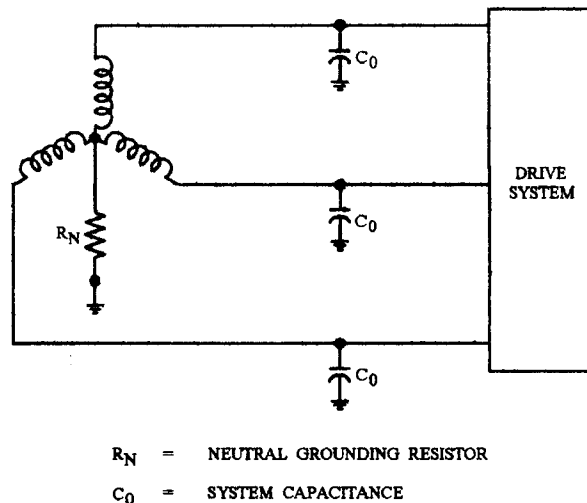

Fig. 9. High-resistance neutral grounding with high-frequency filtering capacitor.

The cause of the problems can best be shown in Fig. 9. The system capacitive reactance is inversely proportional to the frequency. With higher order harmonic voltages present due to the electronic switching of the loads, currents can and do circulate through the neutral grounding resistor. When applying such loads to the system, the harmonic voltage across the resistor should be measured, and an oscilloscope should be used to view the voltage waveform, where both magnitude and frequency can be recorded.

When applying a high-resistance grounded system where there is a significant amount of variable-speed drives, the resultant zero-sequence currents caused by the switching of the drives and the capacitance of the system must be taken into consideration. Due to the relatively high amount of neutral resistance, typically, in the 60–300- Ω range, a small amount of high-frequency current can result in a significant voltage across the resistor.

As an example of this problem, a 575-V 870-kVA drive supplying a 945-hp motor was inspected and found to have a significant voltage across the grounding resistor on the transformer. The transformer was rated 1000 kVA, 4.16-kV delta primary—575 (Y)/332-V secondary with a 670-V 4.5-A 150- Ω grounding resistor. A high-frequency (800⁺ Hz) current was found to be flowing through the resistor. The resultant voltage across the resistor was measured between 100–110-V rms from a 0.66-A current. As can be easily seen, such a high voltage across the resistor creates a problem when that voltage is used for alarm or trip.

There are most likely a number of solutions to this problem. One is to place a reactor in series with the resistor and a capacitor in parallel with the series combination of the resistor and reactor (Fig. 10). This solution would provide blocking of high-frequency currents through the resistor and bypassing the high-frequency currents at the same time. However, further inspection of the circuit will reveal that the parallel capacitor will provide a low-impedance path for the high-frequency currents and act as a high impedance for the low-frequency, 50 or 60 Hz, ground-fault currents (Fig. 11). In other words, the

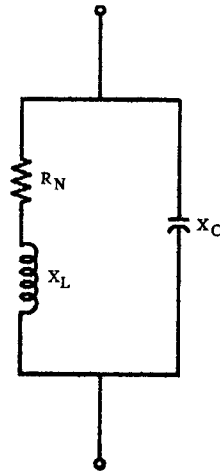

Fig. 10. Neutral R-L-C impedance.

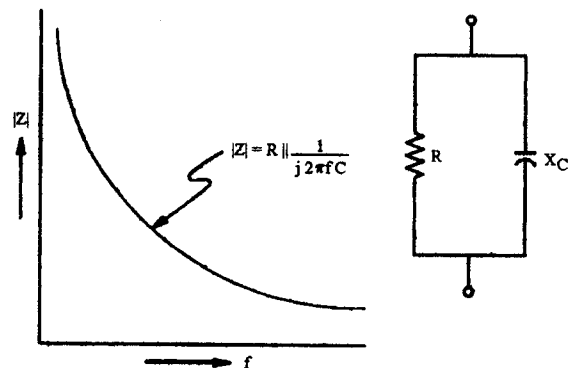

Fig. 11. Neutral R-C impedance characteristics.

capacitor acts as a high-pass filter to eliminate the nuisance current, but will allow the fault current to flow through the resistor for alarming and/or tripping.

In the above example, a 10- μ F 600-V capacitor was inserted in parallel with the resistor. The voltage across the resistor was reduced from approximately 100–110 V to 12.5–15 V. The voltage reduction results were quite significant. With the high-frequency nuisance voltage being reduced to a relatively low value, a reasonable voltage setting can be made for alarm and/or trip when a ground fault occurs.

A secondary benefit, which was observed on the above test, was a reduction in the high-frequency noise on the phase voltages. The original phase-to-ground voltage waveform was quite distorted, resulting in a fluctuating rms phase voltage of 345–355 V. Upon insertion of the capacitor into the circuit, the voltage waveform was much less distorted and the voltage was a stable 335-V rms.

VIII. APPLICATION FOR EMERGENCY SYSTEMS

Another use of the high-resistance grounding is for emergency power systems, as described in NEC Article 700. According to NEC 700-26, ground-fault protection is not required. However, the article further states that ground-fault indication should be provided. The use of the high-resistance grounded system can provide the reliability required

for the emergency power system, as well as the ground-fault indication.

IX. INSTALLATION AND TESTING

The installation and testing of the high-resistance grounding system is important. The installation should be performed in accordance with the engineer's and/or manufacturer's specific instructions that should include these basic steps.

- 1) With the system deenergized, install the high-resistance grounding system. On a "wye"-connected transformer or generator, the resistor is connected between the ground bus and the neutral. On a "delta" system, the auxiliary grounding transformer is needed to be properly connected to the 480-V system bus. Proper installation and safety procedures need to be strictly followed.
- 2) The charging current should be measured using proper testing procedures. The entire system should be energized during this test to ensure that the maximum charging (capacitive) current is measured. The following steps are required.

- a) With the tapped grounding resistor, a conservative resistance value should be connected to the system.
- b) The system should be energized initially with the resistor in place to test for ground faults. Little or no voltage should be present across the resistor. For a solid ground fault on a 480-V system, a voltage of approximately 277 V would be present. For a motor winding or high-resistance ground fault, voltages lower than 277 V are measured. If a ground fault is found, it must be removed prior to the next step.
- c) The system should be deenergized and the grounding resistor disconnected from the system.
- d) Using an isolated circuit with the circuit breaker open, install the test circuit as shown in Fig. 12(a).
- e) Energize the entire circuit, slowly reduce the resistance to zero, and measure the charging (capacitive) current.
- f) Verify that the calculated resistive current I_R is greater than I_C measured in the above step. To calculate I_R , divide the voltage V_N by R

$$I_R = \frac{V_N}{R} \text{ A.} \quad (6)$$

- g) Deenergize the system, properly set the tap, reinstall the grounding resistor, and again place a fault on the system, as shown in Fig. 12(b).
- h) Measure and record the ground-fault current in the resistor and the voltage across the resistor.
- i) Test and place settings on any protective devices.
- j) Remove the fault and place the system in service.

X. CONCLUSIONS

High-resistance grounding has a good track record in the petrochemical industry for a number of reasons.

- Capacitive current on LV systems (440–600 V) is low enough (less than 5 A) that resistive controlled current can

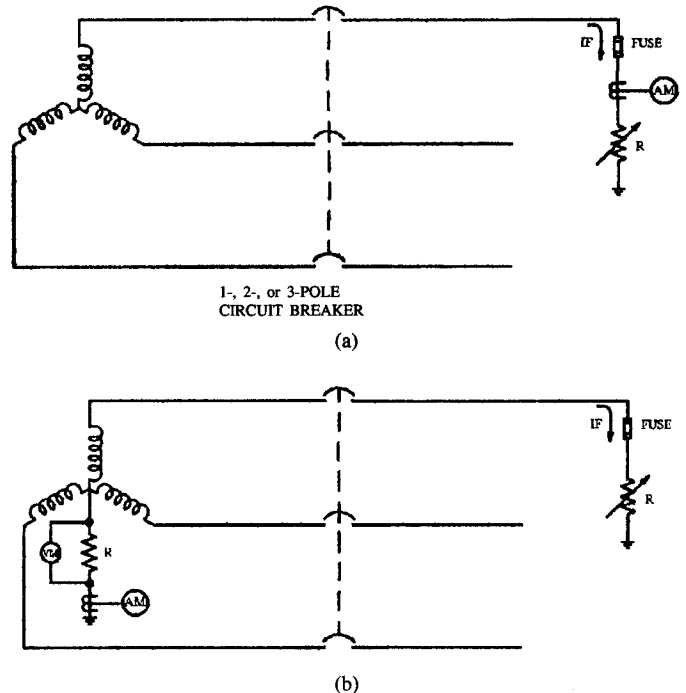

Fig. 12. (a) Test circuit for measuring capacitive current. (b) Test circuit for measuring voltage and current at grounding resistor.

be kept low to avoid escalating the fault current resulting in equipment damage.

- Proper application of the high-resistance grounded system will limit the transient overvoltages of arcing faults to an acceptable value.
- The application of high-resistance grounding has historically been limited to three-phase three-wire systems. However, this paper has shown that three-phase four-wire loads and/or one-phase loads can be accommodated with the use of an isolation transformer.
- The proper use of grounding and bonding is still important, even though the normal ground-fault current may be limited to a few amperes. In the event of a phase-to-phase fault involving ground, the ground currents could be quite high.
- Although the high-resistance grounding is quite simple, a detailed design is still required in order to adequately select and size the equipment. Once the system is installed, it requires testing in order to adequately select the optimum resistance value. Taps on the resistor are beneficial for the final setting of the ground resistance.
- High-resistance grounded systems may be used to trip a breaker or initiate an alarm. If used for alarming, the ground-fault location needs to be determined and isolated in a reasonable amount of time. While the ground fault persists, the voltage on the two ungrounded phases can elevate to 73% greater than normal line-to-ground voltage.
- A high-resistance grounded system will minimize the chances of serious "burndown" damage and severe arc flash damage. The result is safer for both the equipment and personnel.

- A high-resistance grounded system can be successfully used on systems with rectifiers, dc drives, ac drives, and other harmonic current producing circuits. The proper placement of a capacitor across the resistor will help filter the high-frequency current.

This paper has shown the benefits of high-resistance grounding for continuous process industries. When reliability and limitation of ground-fault current is essential, a high-resistance grounded system is recommended. With the proper design and testing, a high-resistance grounded system provides the safety and reliability necessary for a petrochemical or other heavy industry. As such, the high-resistance grounded system should become a standard of the industry, and the solidly grounded system should only be used where the high-resistance grounded system cannot be used for a three-phase four-wire system.

REFERENCES

- [1] *National Electrical Code*, National Fire Protection Association, Quincy, MA, 1995.
- [2] J. L. Blackburn, *Symmetrical Components for Power Systems Engineering*. New York: Marcel Dekker, 1993, pp. 104–108.
- [3] W. D. Bolin and C. C. Kumin, "480 volt corner grounded delta—Friend or foe," presented at the 1988 IEEE Petroleum and Chemical Industry Technical Conf., Dallas, TX, Sept. 1988, Paper PCIC-88-31.
- [4] B. Bridger, Jr., "High resistance grounding," *IEEE Trans. Ind. Applicat.*, vol. IA-19, pp. 15–21, Jan./Feb. 1983.
- [5] D. Dalasta, B. G. Bailey, and N. Peach, "Ground fault protection," in *Proc. IEEE Industry and General Applications Group, Industrial and Commercial Power Systems Conf.*, Detroit, MI, May 7, 1971, pp. 111–129.
- [6] J. R. Dunki-Jacobs, "The escalating arcing ground fault phenomenon," presented at the 1985 IEEE Petroleum and Chemical Industry Technical Conf., Dallas, TX, Sept. 1985, Paper PCIC-85-3.
- [7] ———, "The reality of high-resistance grounding," presented at the 1976 IEEE Petroleum and Chemical Industry Technical Conf., Philadelphia, PA, Aug./Sept. 1976, Paper PCIC-76-6.
- [8] F. K. Fox and L. B. McClung, "Ground fault tests on a high resistance grounded electrical distribution system of a modern large chemical plant—I," *IEEE Trans. Ind. Applicat.*, vol. IA-10, pp. 581–600, Sept./Oct. 1974.
- [9] *Application Engineering Information—Generator Neutral Grounding*, General Electric Co., Schenectady, NY, 1964.
- [10] *Industrial Power Systems Data Book*, General Electric Co., Schenectady, NY, 1964.
- [11] S. Jamil, R. A. Jones, and L. B. McClung, "Arc and flash burn hazards at various levels of an electrical system," presented at the 1995 IEEE Petroleum and Chemical Industry Technical Conf., Denver, CO, Sept. 1995, Paper PCIC-95-34.
- [12] C. R. Mason, *The Art and Science of Protective Relaying*. New York: Wiley, 1956, pp. 208–214.
- [13] L. B. McClung and B. W. Whittington, "Ground fault tests on a high resistance grounded 13.8 kV electrical distribution system of a modern large chemical plant—Part II," *IEEE Trans. Ind. Applicat.*, vol. IA-10, pp. 581–600, Sept./Oct. 1974.
- [14] ———, "Industrial plant protection with high resistance grounding," in *Proc. IEEE Industry and General Applications Group, Industrial and Commercial Power Systems Conf.*, Detroit, MI, May 6, 1971, pp. 105–110.
- [15] L. J. Powell, Jr., "Influence of third harmonic circulating currents in selecting neutral grounding devices," *IEEE Trans. Ind. Applicat.*, vol. IA-9, pp. 672–679, Nov./Dec. 1973.
- [16] G. N. Wang *et al.*, "High resistance grounding and selective ground fault protection for a major industrial facility," presented at the 1983 IEEE Petroleum and Chemical Industry Technical Conf., Denver, CO, Sept. 1983, Paper PCIC-83-12.
- [17] *System Neutral Grounding and Ground Fault Protection*, Westinghouse Industrial and Commercial Power System Application Series, Westinghouse Electric Corp., Newark, NJ, Jan. 1978.
- [18] L. Yu and R. T. Beck, "Safe grounding practices and recommendations for industrial facilities," presented at the 1992 IEEE Petroleum and Chemical Industry Technical Conf., San Antonio, TX, Sept. 1992, Paper PCIC-92-52.



John P. Nelson (S'73–M'76–SM'82–F'97) received the B.S. degree from the University of Illinois, Champaign-Urbana, and the M.S. degree from the University of Colorado, Denver, in 1970 and 1975, respectively, both in electrical engineering.

He was with Public Service Company of Colorado between 1969–1979, during which time he was assigned to the Electric Engineering Department, Engineering Services Department, and the Fuel Supply Development Division. From 1979 to 1984, he was with Power Line Models, Inc., Evergreen, CO, where he was a principal and Vice President and was active in the design and construction of electrical substations. He founded NEI Electric Power Engineering, Inc. (formerly Nelson Engineering, Inc), Arvada, CO, of which he is President and CEO and involved in all aspects of electric power systems engineering and field services. He also currently holds the position of Adjunct Professor in the Department of Electrical Engineering, University of Colorado, Denver. He is the author of several papers which have been published in the IEEE TRANSACTIONS ON INDUSTRY APPLICATIONS.

Mr. Nelson is an active member of the Petroleum and Chemical Industry Committee of the IEEE Industry Applications Society and a Registered Professional Engineer in numerous states.



Pankaj K. Sen (S'71–M'74–SM'90) received the B.E.E. degree (with honors) from Jadavpur University, Calcutta, India, and the M.Eng. and Ph. D. degrees in electrical engineering from the Technical University of Nova Scotia, Halifax, NS, Canada.

He is currently a Professor and Chair of the Department of Electrical Engineering, University of Colorado, Denver. His research interests include application problems in machines and power systems and power engineering education. He has published more than 55 articles in various archival journals

and conference proceedings.

Dr. Sen is a Registered Professional Engineer in the State of Colorado.